



CANON SOLUTIONS AMERICA DYE SUBLIMATION SOLUTIONS

Full Solutions—Full Support

Whether you are just beginning your journey into dye sublimation printing or are a seasoned veteran in the market, having a partner who is there to support you is invaluable.

Canon Solutions America Offers the complete solution from financing to service and support, including:

- Dye Sublimation Printers
- Calendars and Heat Presses
- Sewing Solutions
- Support Services
- Canon Financial Services



Overview Of DGI Print Solutions

Canon Solutions America has partnered with DGI, a manufacturer with deep roots in dye sublimation, to deliver solutions which combines DGI's highly productive printers with Canon Solutions America's robust support services and market expertise.

POSEIDON



- 64" paper transfer dye sublimation printer
- 4-color (CMYK) or 6-color (CMYK + fluorescent yellow & pink)
- Designed for unattended printing
- Industrial production printer

FT-3204X



- 130" hybrid (Paper Transfer & Direct to Fabric) dye sublimation printer
- 4-color (CMYK)
- Productive entry point into the 10' dye sublimation market

FH-3204



- 126" hybrid (Paper Transfer & Direct to Fabric) dye sublimation printer
- 4-color (CMYK) or 6-color (CMYK + fluorescent yellow & pink)
- Mesh printing

DGI FH-3204

126" Hybrid Dye Sublimation Printer



MEDIA	
Max Print Width:	126"
Max Roll Size:	9.4" diameter x 126" width
Max Roll Weight:	220 lbs
Max Media Thickness:	0.0393" (Fabric: 110-260 gsm, Paper 72-150 gsm)
TECHNOLOGY	
Supported Print Methods:	Paper Transfer & Direct to Fabric
Print Heads:	Kyocera printheads (4 Color = 2 ph or 4 ph, 6 Color = 3 ph)
Options:	4 Color with 2 or 4 print heads, or 6 Color with 3 print heads
Ink:	Dye Sublimation: Cyan, Magenta, Yellow, Black, Fluorescent Yellow, Fluorescent Pink
Ink Packaging:	5 kg box
Features:	Mesh Printing, Mobile Monitoring
Electricity Req:	Single Phase 220 V, 50/60 Hz AC, 25 A (Printer: 5 A, Dryer: 20 A), Ground 0-10 VAC
Environmental:	Temperature: 72.5-81.5°F, Humidity: 40-70%
Compressor:	Pressure 5 kgf/cm ² , 1 HP, 100 LPM
Interface:	TCP/IP
SOFTWARE	
RIP Compatibility:	Wasatch TX, Ergosoft, Caldera, Onyx
DGI PC Controller Req:	CPU i7 or higher RAM Over 16 GB USB 3.0 or higher LAN 2 1 Gbps Ethernet ports
<i>*separate PC for RIP required</i>	
PRODUCTIVITY	
Print Speed 4PH:	3,230 sf/hr 1668 sf/hr 1022 sf/hr 538 sf/hr 376 sf/hr
Print Resolution:	300 x 600 dpi 600 x 600 dpi 600 x 600 dpi 600 x 1200 dpi 600 x 1,200 dpi 1Pass 2Pass 4Pass 8Pass 12Pass
Print Speed 2-3PH:	904sf/hr 635sf/hr 484sf/hr
Print Resolution:	600 x 600 dpi 600 x 900 dpi 600 x 1200 dpi 4Pass 6Pass 8Pass
WEIGHTS AND DIMENSIONS	

CRATED	
Length	212.6"
Width	60.7"
Height	84.4"
Weight	4,630 lbs.
UNCRATED	
Length	206.3"
Width	47.25"
Height	67"
Weight	2,822 lbs.

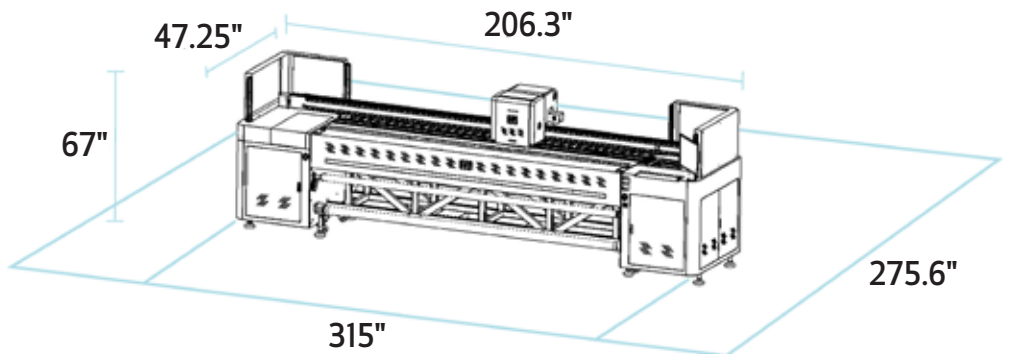

DGI FT-3204X

130" Hybrid Dye Sublimation Printer



MEDIA					
Max Print Width:	130.7"				
Max Roll Size:	11.8" diameter x 132.6" Width				
Max Roll Weight:	176 lbs				
Max Media Thickness:	0.03"				
TECHNOLOGY					
Supported Print Methods:	Paper Transfer & Direct to Fabric				
Print Heads:	Panasonic printhead (8 heads)				
Ink:	Dye Sublimation: Cyan, Magenta, Yellow, Black				
Ink Packaging:	Case of 6 1 kg Bottles				
Features:	Mesh Printing				
REQUIREMENTS					
Electricity Req:	Single Phase 220 V, 50/60 Hz, AC, 40 A (Printer 5 A, 6.6 Kw Heater 35 A)				
Environmental:	Temperature: 72.5~81.5 °F, Humidity: 40~70%				
Interface:	TCP/IP , USB 3.0				
SOFTWARE					
RIP Compatibility:	Wasatch TX, Ergosoft, Caldera, Onyx				
DGI PC Controller Req:	CPU i7 or higher RAM Over 16 GB USB 3.0 or higher LAN 2 1 Gbps Ethernet ports				
PRODUCTIVITY					
Print Speed:	2,690 sf/hr	1614 sf/hr	1,130 sf/hr	861 sf/hr	592 sf/hr
Print Resolution:	360 x 360 dpi 1Pass	720 x 360 dpi 2Pass	540 x 720 dpi 2Pass	720 x 720 dpi 4Pass	720 x 1,080 dpi 6Pass
<i>Separate PC for RIP required</i>					
WEIGHTS AND DIMENSIONS					
CRATED					
Length	204.8"				
Width	45.3"				
Height	76.4"				
Weight	3,616 lbs				
UNCRATED					
Length	197.7"				
Width	41.4"				
Height	61.5"				
Weight	2,073 lbs				

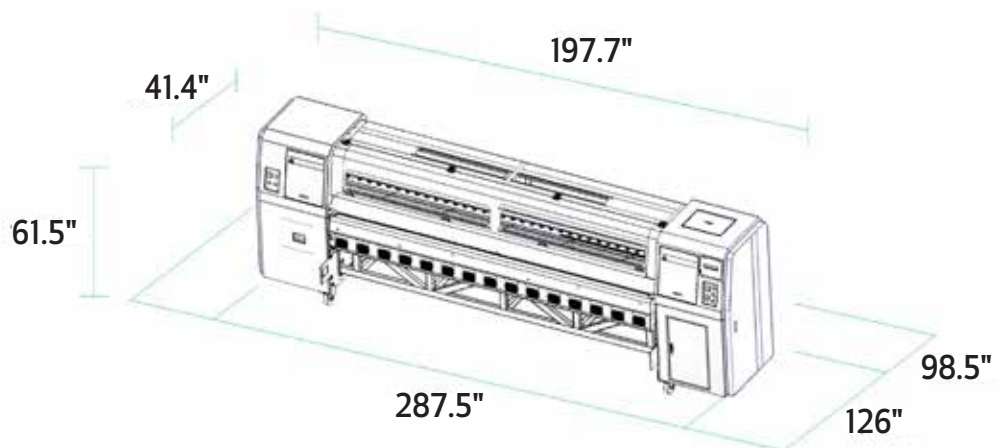

POSEIDON

64" Paper Transfer Dye Sublimation Printer



MEDIA	
Max Print Width:	64.17"
Max Roll Size:	7.8" diameter, 64.96" width
Max Roll Weight:	66 lbs
Max Media Thickness:	0.0393"
TECHNOLOGY	
Supported Print Methods:	Paper Transfer
Print Heads:	Kyocera printheads (4 Color = 2 ph, 6 Color = 3 ph)
Options:	4 or 6 Colors
Ink:	Dye Sublimation: Cyan, Magenta, Yellow, Black, Fluorescent Yellow, Fluorescent Pink
Ink Packaging:	Case of 10 1 kg bottles
Features:	Sleep mode for unattended operation, mobile monitoring
REQUIREMENTS	
Electricity Req:	2 connectors; Printer: Single Phase 220 V (50/60 Hz, AC) 15 A, Heater: Single Phase 220 V (50/60 Hz, AC) 10 A
Environmental:	Temperature: 72.5~81.5°F, Humidity: 40-60%
Interface:	TCP/IP, USB 3.0
SOFTWARE	
RIP Compatibility:	Wasatch TX, Ergosoft, Caldera, Onyx
DGI PC Controller Req:	CPU i7 or higher RAM Over 16 GB USB 3.0 or higher LAN 2 1 Gbps Ethernet ports
<i>*separate PC for RIP required</i>	
PRODUCTIVITY	
Print Speed:	2,260 sf/hr 1237 sf/hr 861 sf/hr 592 sf/hr 430 sf/hr
Print Resolution:	600 x 300 dpi 1Pass 600 x 600 dpi 2Pass 600 x 600 dpi 4Pass 600 x 900 dpi 6Pass 600 x 1,200 dpi 8Pass
WEIGHTS AND DIMENSIONS	

CRATED	
Length	137.8"
Width	45.3"
Height	67.0"
Weight	1,455.1 lbs
UNCRATED	
Length	129.9"
Width	41.3"
Height	53.1"
Weight	970 lbs

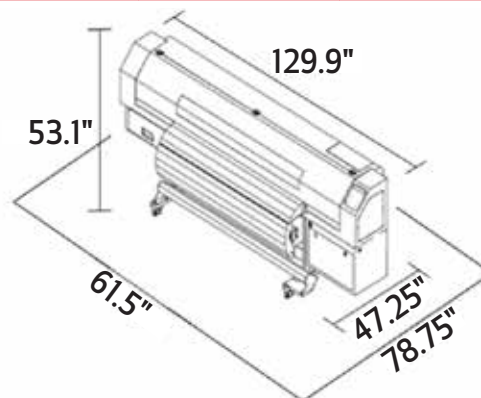

Large Format Solutions
100 Park Blvd., Itasca, IL 60143

1-800-842-4534 | 1-630-250-6551
us.info@csa.canon.com CSA.CANON.COM